



Parts Manual
X17 ECO EXTRACTOR

PREFACE

Thank you for your purchase of the new industry standard for extractors. Minuteman International takes great pride in offering the most dependable, reliable and best value in industrial power extractors. We set the standard.

Our Customer Service Department would like to hear from you. If you see any errors, omissions or something that needs clarification in this Parts Catalog please let us know. We are working hard towards continually improving our processes to bring you the best you deserve. Please copy the form below, fill out and comment on how you found our catalog.

Thank you!

The Minuteman International Team

Name: _____

Title: _____

Company Name: _____

Address: _____

Country: _____

Type of equipment or model number: _____

Comments: _____

Please return to:

Customer Service Manager
Minuteman International, Inc.
14N845 U.S. Route 20
Pingree Grove, Illinois 60140 USA

Phone: (800) 323-9420

Email: tech@minutemanintl.com

Technical Specifications

Model: X17 ECO

Models: X17115, X17115HP, X17115PLUS, X17115PLUSHP
X17230, X171230HP, X17230PLUS, X17230A, X17230SA

Models	X17/X17 HP	X17 Plus/ Plus HP
Cleaning Path Width	17" (43 cm)	17" (43 cm)
Solution Tank	9 gallon (34 lt.)	11 gallon (42 lt.)
Recovery Tank	7.5 gallon (28.4lt.)	10 gallon (37.9lt.)
Vacuum Motors	2 HP 3-stage	2 HP 3-stage
Solution Pressure	50 psi / 100 psi	50 psi / 100 psi
Brush Motor	1/6 HP	1/6 HP
Tank Construction	Polyethylene	Polyethylene
Rated Voltage	Available in115V and 230V	Available in115V and 230V
Rear Wheels	10" non-mark- ing	10" non-marking
Waterlift	118"	118"
Power Cord	50 ft.	50 ft.
Brush Speed	1800 RPM	1800 RPM
CFM	99	99
Spray Jets	Dual jet	Dual jet
Options	Scrub wand,ET tool, 15' vachose	Scrub wand,ET tool, 15' vachose

For Safety When Servicing or Maintaining Machine

- Stop on level surface.
- Disconnect the power to the machine.
- Avoid moving parts. Do not wear loose jackets, shirts, or sleeves when working on machine.
- When working around machine use protective clothing and safety glasses. Remove metal jewelry.
- Do not clean machine with a pressure washer.
- Authorized personnel must perform repairs and maintenance. Use Minuteman supplied replacement parts.

Table of Contents

Technical Specifications.....	3
Safety Information.....	3
Main Assembly Rear View	6
Main Assembly BOM	7
Solution Tank Assembly Front View.....	8
Solution Tank Assembly Rear View	9
Solution Tank Assembly BOM.....	10
Solution Tank Assembly (Plus Models) Front View.....	11
Solution Tank Assembly (Plus Models) Rear View	12
Solution Tank Assembly (Plus Models) BOM.....	13
Recovery Tank Assembly.....	14
Recovery Tank Assembly BOM	15
Recovery Dome Lid Assembly.....	16
Spray Bar Assembly	17
Handle Assembly (Pg 1 of 2)	18
Handle Assembly (Pg 2 of 2)	19
Handle Assembly BOM.....	20
Back Panel Assembly	21
Chassis Sub-Assembly	22
Chassis Sub-Assembly BOM (Pg 1 of 2).....	23
Chassis Sub-Assembly BOM (Pg 2 of 2).....	24
Brush Head Assembly	25
Brush Head Assembly BOM	26
Valve-Filter Assembly	27
Pump Assembly.....	28
Wiring Diagrams - 115V.....	30
Wiring Schematic 115V, Handle Assembly	30
Wiring Schematic 115V, Wire Harness	31
115V Electrical Schematic Reference Numbers.....	32
Wiring Diagrams - 230V.....	33
Wiring Schematic 230V, Handle Assembly	33
Wiring Schematic 230V, Wire Harness	34
230V Electrical Schematic Reference Numbers	35
Warranty	36

Main Assembly Rear View

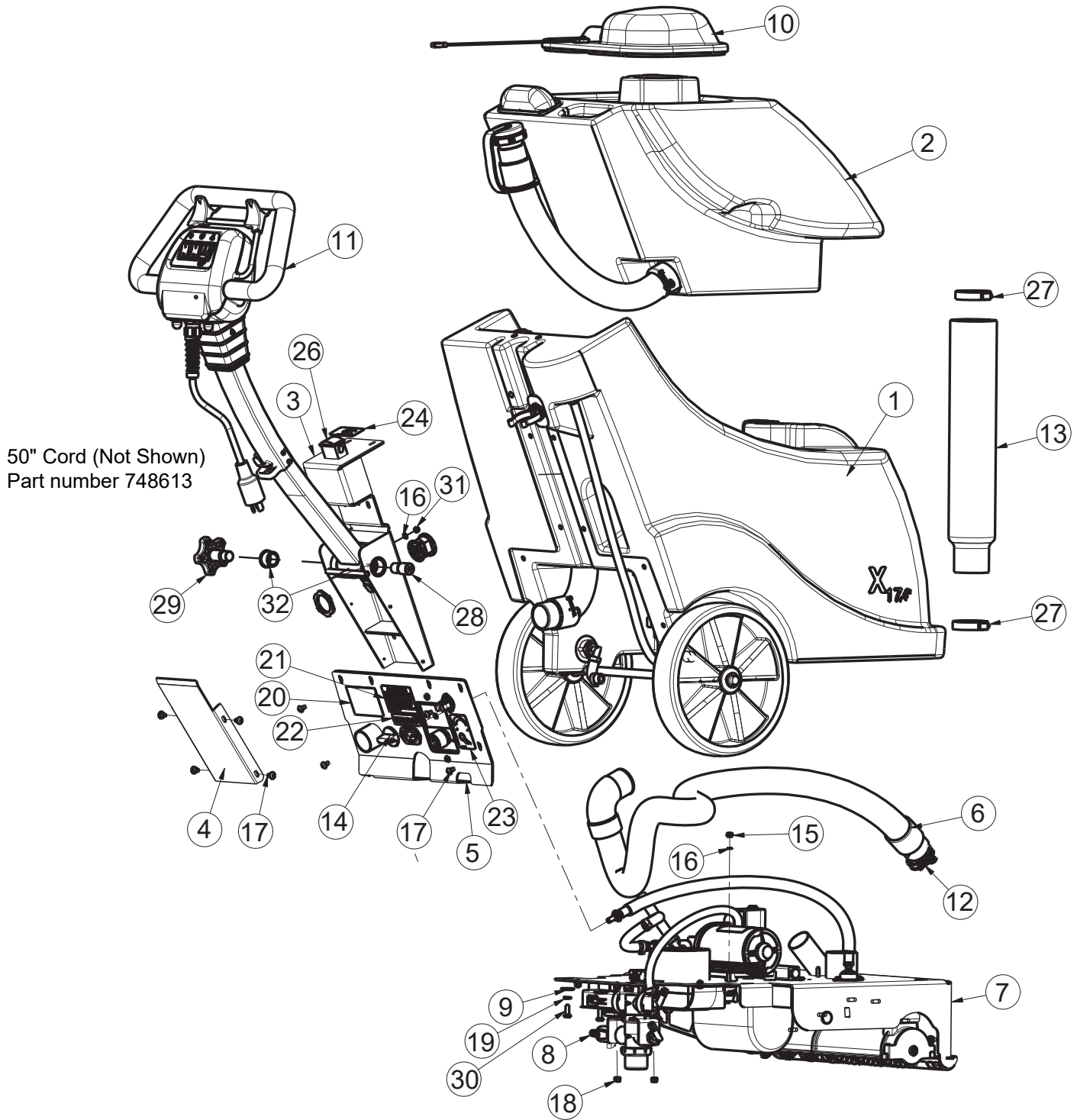

Main Assembly BOM

BILL OF MATERIAL				
ITEM	PART NO.	QTY	DESCRIPTION	MODEL INFO.
1	173010	1	ASY-SOLUTION TANK 115VAC BURGUNDY	115V MODEL
	173010-230		ASY-SOLUTION TANK 230VAC BURGUNDY	230V MODEL
	173180		SOL TANK ASSEMBLY, X17 PLUS	115V PLUS MODEL
	173188		SOL TANK ASSEMBLY, X17 PLUS, 230V	230V PLUS MODEL
	173010-230A		ASY-SOLUTION TANK ORANGE 230VAC	230V AUSTRALIAN MODEL
2	173020	1	RECOVERY TANK ASSY, X17	
	173009		RECOVERY TANK - X17 PLUS	PLUS MODELS ONLY
3	173035	1	HANDLE BRACKET WELDMENT	
4	173036	1	REAR PANEL COVER	
5	173043	1	BACK PANEL ASSEMBLY	
6	173044	1	HOSE, CLEAR VAC	
7	173050	1	CHASSIS ASY, X17-ECO 115VAC	115V AND 115V PLUS MODELS
	173050HP		CHASSIS ASY, X17-ECO 100PSI 115VAC	115V HP AND 115V HP PLUS MODELS
	173050-230		CHASSIS ASY, X17-ECO 230VAC	230V AND 230V PLUS MODELS
	173050-230HP		CHASSIS ASY, X17-ECO 100PSI 230VAC	230V HP MODEL
8	173222	1	ASSY, BALL-VALVE & FILTER; SHIELDED	
9	173080	2	WASHER-FLAT .266 X .875 X .07 SS	
10	173195	1	RECOVERY DOME LID ASSEMBLY	
11	173200	1	HANDLE ASSEMBLY-UL, X17	ALL 115V MODELS
	173201		HANDLE ASSEMBLY-230V, X17	ALL 230V MODELS
12	3303255	1	CLAMP-HOSE 1.75 DIA NOMINAL	
13	320836	1	MUFFLER, VAC MOTOR	
14	452029	1	KNOB-BLK W/1/4 BRASS INSERT	
15	711350	1	NUT-NYLOC 10-32 ZP	
16	711553	2	WASHER-INT TOOTH LOCK #10 ZP	
17	712540	8	SCR-THMS 10-24 X .37 SS	
18	712638	2	NUT-NYLOC 10-24 SS	
19	712758	2	WASHER-LOCK 1/4 SPLIT SS	
20	715047	1	DECAL-CLEAR LAMINATE 2X3	
21	715061	1	DECAL-WARNING GENERAL	
22	715340	1	DECAL-RECT.-USE W/ C46300-00 ONLY	ALL 115V MODELS
	715340-1		DECAL-RECT.-USE W/ C46300-02 ONLY	ALL 230V MODELS
23	715725	1	DECAL, BRUSH PRESSURE & AUX EQ, X17	
24	715726	1	DECAL, AMPERMETER, X17	
25	715950	1	LABEL-PATENT NUMBERS	
26	748671	1	GAUGE, BRUSH PRESSURE X17 230VAC	
27	760859	2	CLAMP-HOSE, 2"	
28	931045	1	PIN-HEX SOC HEAD	
29	931753	1	KNOB-HANDLE	
30	11038072	2	SCR-HH M6-1.0 X 16 ZP CLASS 8.8	
31	12040036	1	NUT-NYLOC M5 X 0.8 ZD CLASS 6	
32	553130054	1	BUSH-FLG LH&RH-HANDLE, 18MM X 24MM	

Solution Tank Assembly Front View

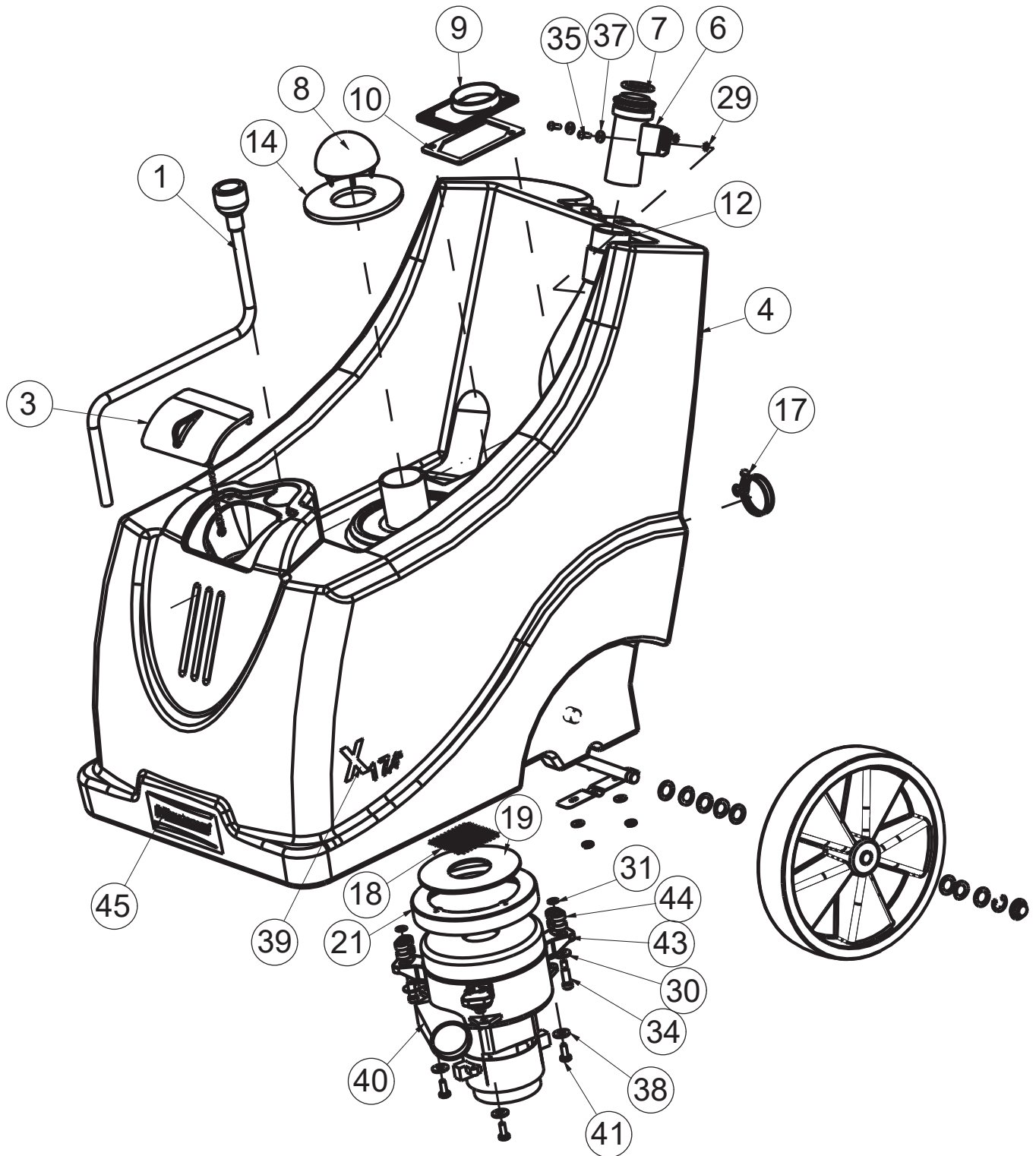

Solution Tank Assembly Rear View

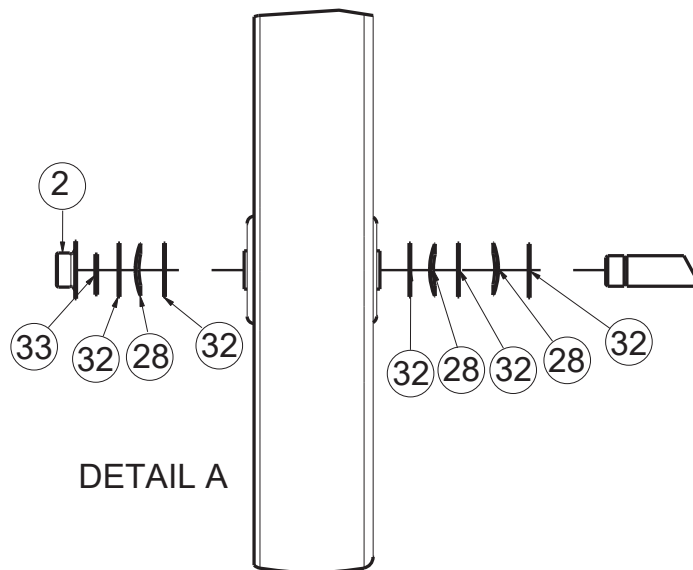
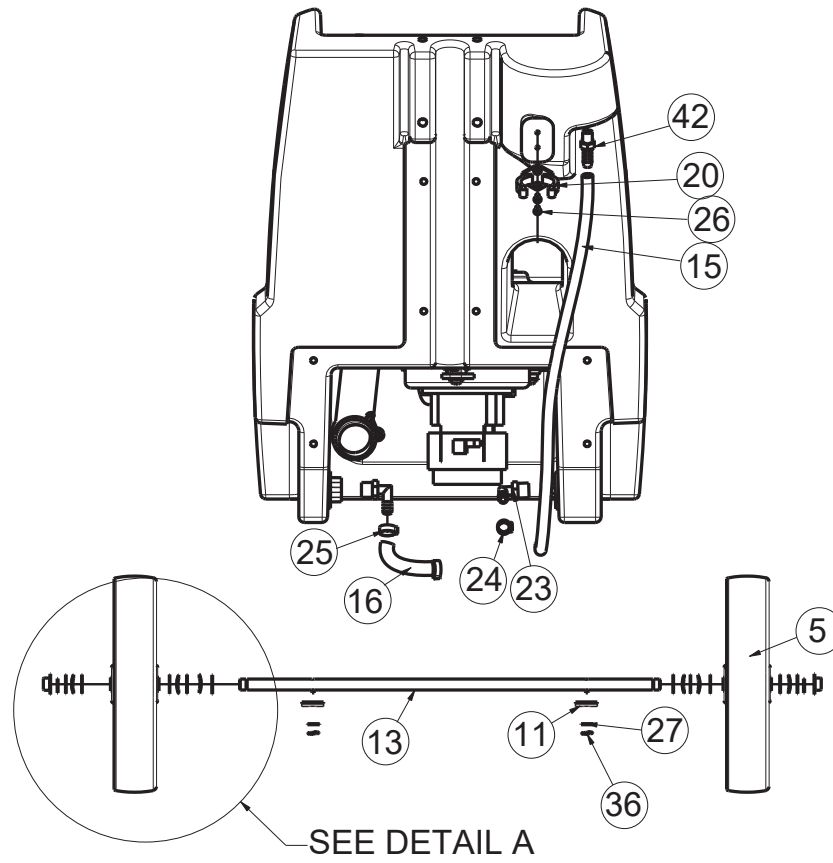

Solution Tank Assembly BOM

BILL OF MATERIAL - 173010 / 173010-230							
ITEM	PART #	QTY	DESCRIPTION	ITEM	PART #	QTY	DESCRIPTION
1	121082	1	FAUCET FILL HOSE ASSY	24	450092	1	CRIMP CLAMP
2	130032	2	WHEEL RETAINER CAP	25	452037	2	CLAMP-CRIMP 17 0R SS
3	172018	1	SOLUTION TANK LID ASSY	26	710530	2	SCR-MC FL HD 8-32 X .50 BRS
4	173001	1	SOLUTION TANK EX17-ECO	27	711504	4	WSR-FLAT 1/4 ID SS
	173001A		SOL. TK EX17-ECO (ORANGE)	28	711524	6	WSR-WAVE .52 X .87 X .01
5	173005	2	WHEEL 10"	29	711534	2	WSR-EXTERNAL LOCK #10
6	173011	1	RECOVERY INLET ASSY	30	711575	3	WSR-FLT .31x.75x.06ST
7	173012	1	O-RING, 1.234 ID x 1.512 OD, SIZE 218	31	711577	3	WSR-FLAT 260 X .50 X .020T
8	173013	1	AIR INLET UMBRELLA	32	711594	10	WSR-FLAT .56 X .88 X .03
9	173014	1	HOSE CONDUIT	33	711713	2	RETAINING RING - "E" TYPE EXT .500
10	173015	1	GASKET, HOSE CONDUIT	34	712070	3	BLT-SHLDR 5/16 X 3/4 X 1/4-20
11	173019	2	AXLE BRACKET	35	712150	2	SC-BHCS, 10-24 X .50 SS
12	173046	1	HOSE, RECOVERY	36	712758	4	WSR-HELICAL 1/4 SS
13	173074	1	AXLE, WHEEL X17 ASSEMBLY	37	712764	2	WSR #10 SS
14	173106	1	GASKET	38	712772	3	WSR-FLAT .344 x .75 x .06 SS
15	173152	1	WATER GAUGE 3/8 I.D x 22 IN	39	715724	2	DECAL X17
16	173157	1	HOSE, 3/8 ID X 4 IN	40	740089-1	1	VAC MOTOR ASY, 115V (115V MODELS)
17	3303255	1	CLAMP-HOSE 1.75 DIA NOMINAL		740260-1		VAC MOTOR ASY, 230V (230V MODELS)
18	260212	1	SCREEN FILTER	41	817306	3	SCR-MC PAN HD M6x16 ZY
19	260294	1	GASKET 260	42	828952	1	FITTING PP 1/4" MPT X 3/8" HOSE BARB
20	260579	1	TOOL CLIP, 1.5" HOSE	43	553530122	3	CLAMP VAC. MOTOR ASSY
21	290017	1	VAC MOTOR GASKET	44	553530123	3	GROMMET, VACUUM MOTOR
22	361218	1	CABLE TIE, BLACK	45	715914W	1	DECAL, MINUTEMAN, WHITE
23	450040	2	FTG-90 3/8MPT X 3/8 BARB NYL				

Solution Tank Assembly (Plus Models) Front View

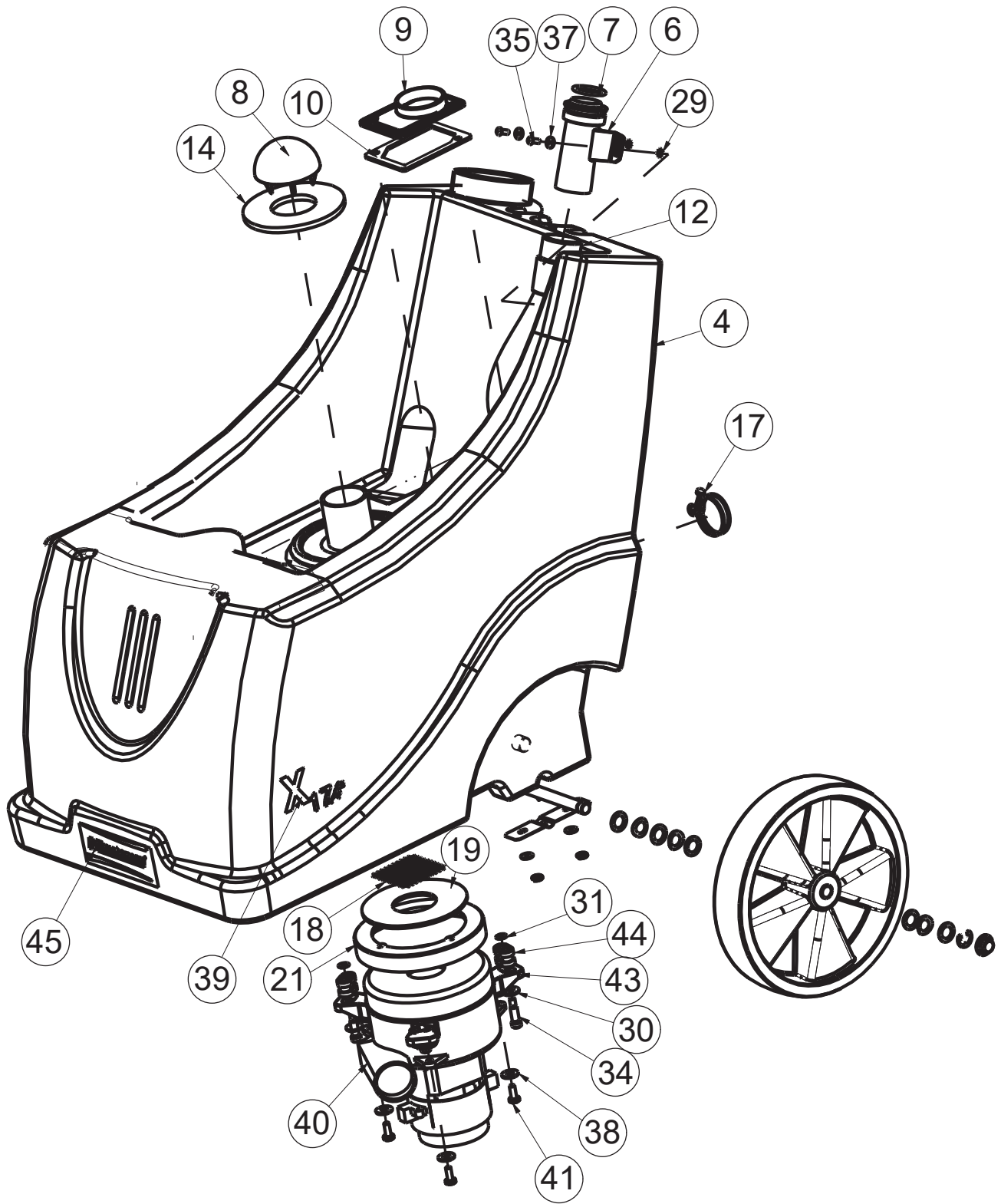

Solution Tank Assembly (Plus Models) Rear View

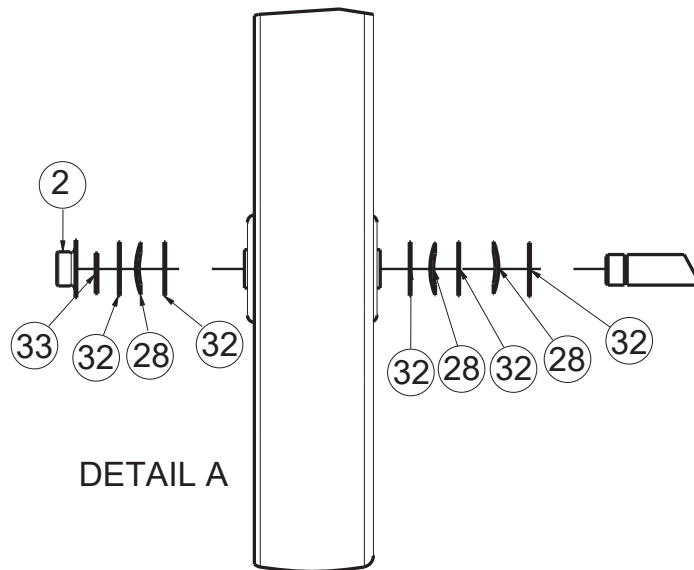
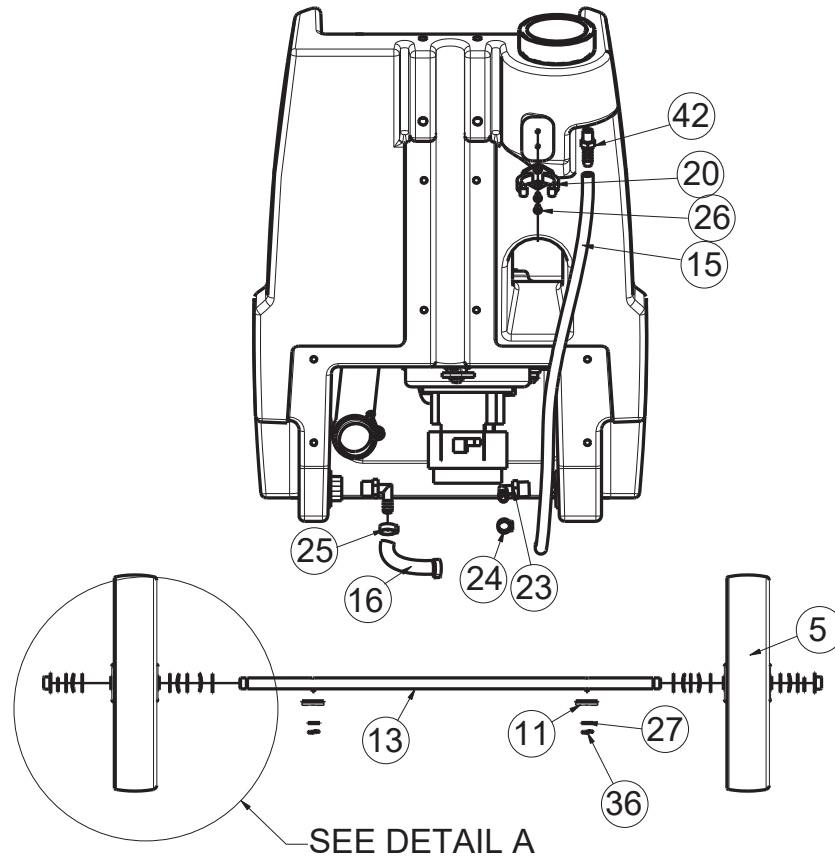

Solution Tank Assembly (Plus Models) BOM

BILL OF MATERIAL - 173180							
ITEM	PART #	QTY	DESCRIPTION	ITEM	PART #	QTY	DESCRIPTION
2	130032	2	WHEEL RETAINER CAP	25	452037	2	CLAMP-CRIMP 17 0R SS
4	173008	1	SOLUTION TANK - X17 PLUS	26	710530	2	SCR-MC FL HD 8-32 X .50 BRS
5	173005	2	WHEEL 10"	27	711504	4	WSR-FLAT 1/4 ID SS
6	173011	1	RECOVERY INLET ASSY	28	711524	6	WSR-WAVE .52 X .87 X .01
7	173012	1	O-RING, 1.234 ID x 1.512 OD, SIZE 218	29	711534	2	WSR-EXTERNAL LOCK #10
8	173013	1	AIR INLET UMBRELLA	30	711575	3	WSR-FLT .31x.75x.06ST
9	173014	1	HOSE CONDUIT	31	711577	3	WSR-FLAT 260 X .50 X .020T HK
10	173015	1	GASKET, HOSE CONDUIT	32	711594	10	WSR-FLAT .56 X .88 X .03
11	173019	2	AXLE BRACKET	33	711713	2	RETAINING RING - "E" TYPE EXT .500
12	173046	1	HOSE, RECOVERY	34	712070	3	BLT-SHOULDER 5/16 X 3/4 X 1/4-20
13	173074	1	AXLE, WHEEL X17 ASSEMBLY	35	712150	2	SC-BHCS, 10-24 X .50 SS
14	173106	1	GASKET	36	712758	4	WSR-HELICAL 1/4 SS
15	173152	1	WATER GAUGE 3/8 I.D x 22 IN	37	712764	2	WSR #10 SS
16	173157	1	HOSE, 3/8 ID X 4 IN	38	712772	3	WSR-FLAT .344 x .75 x .06 SS
17	3303255	1	CLAMP-HOSE 1.75 DIA NOMINAL	39	715026	2	DECAL-X17 PLUS
18	260212	1	SCREEN FILTER	40	740089-1	1	VAC MOTOR ASY, 115V
19	260294	1	GASKET 260	41	817306	3	SCR-MC PAN HD M6x16 ZY
20	260579	1	TOOL CLIP, 1.5" HOSE	42	828952	1	FITTING PP 1/4" MPT X 3/8" HOSE BARB
21	290017	1	VAC MOTOR GASKET	43	553530122	3	CLAMP VACUUM MOTOR ASSEMBLY
22	361218	1	CABLE TIE, BLACK	44	553530123	3	GROMMET, VACUUM MOTOR
23	450040	2	FITTING-90 3/8MPT X 3/8 BARB NYLON	45	715914W	1	DECAL, MINUTEMAN W/ SWOOSHES, WHITE
24	450092	1	CRIMP CLAMP 27/64" TO 17/32"				

Recovery Tank Assembly

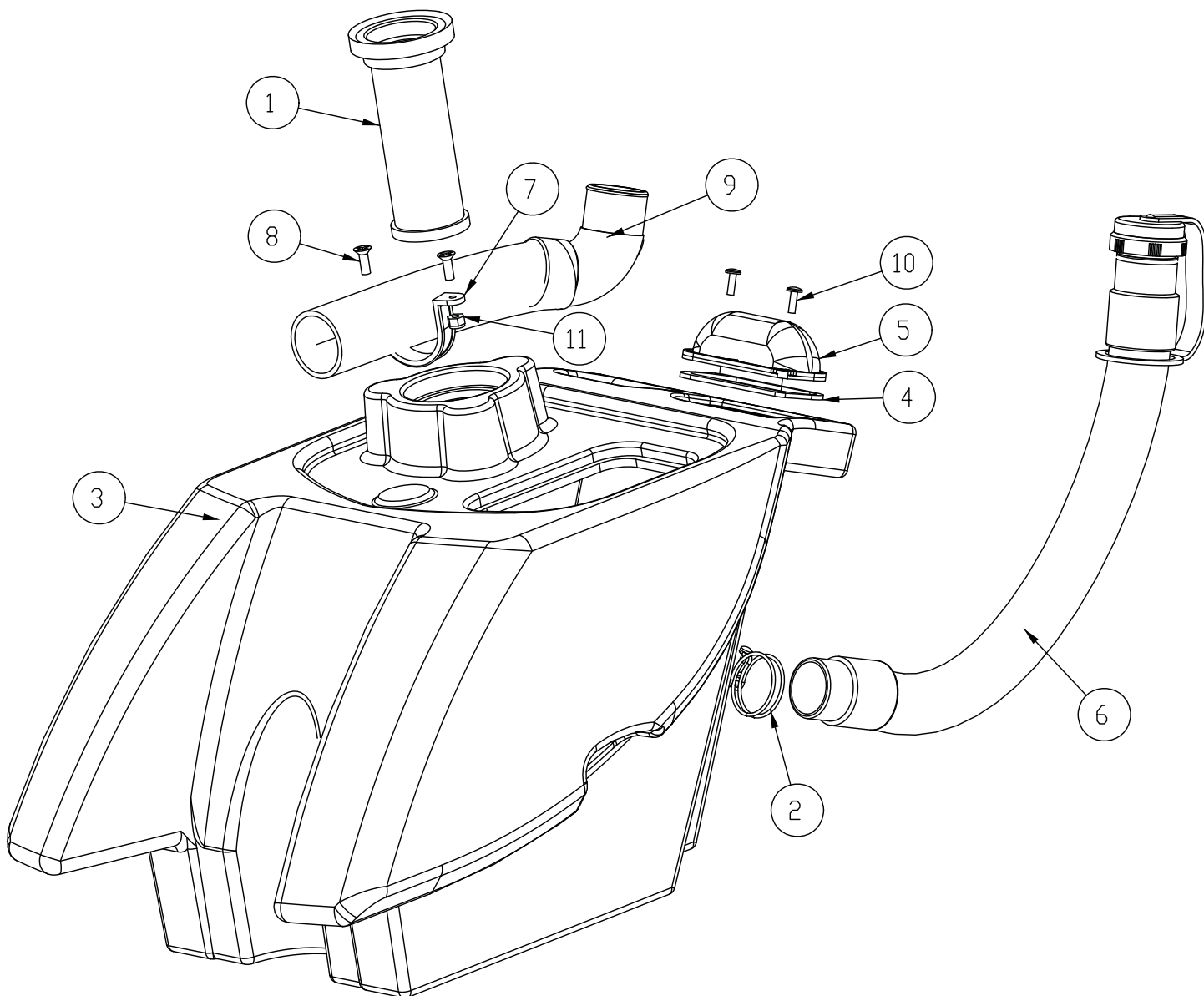

Recovery Tank Assembly BOM

BILL OF MATERIAL - 173020 / 173190 (PLUS MODELS)			
ITEM	PART NO.	QTY	DESCRIPTION
1	172132	1	SCREENED FLOAT
2	3303255	1	CLAMP-HOSE 1.75 DIA NOMINAL
3	173002	1	RECOVERY TANK EX17-ECO
	173009		RECOVERY TANK - X17 PLUS (PLUS MODELS ONLY)
4	173025	1	RECOVERY WINDOW GASKET
5	173026	1	RECOVERY WINDOW
6	173063	1	HOSE, DUMP
7	173099	1	PLASTIC TWO-HOLE STRAP
8	173100	2	SCR FL HD 1/4-20 x 3/4 SS
9	173104	1	HOSE, RECOVERY 12.5"
10	712536	2	SCR-MC 10-24 X .62 TH SS
11	712667	2	NUT, HEX 1/4-20 NYLOC SS

Recovery Dome Lid Assembly

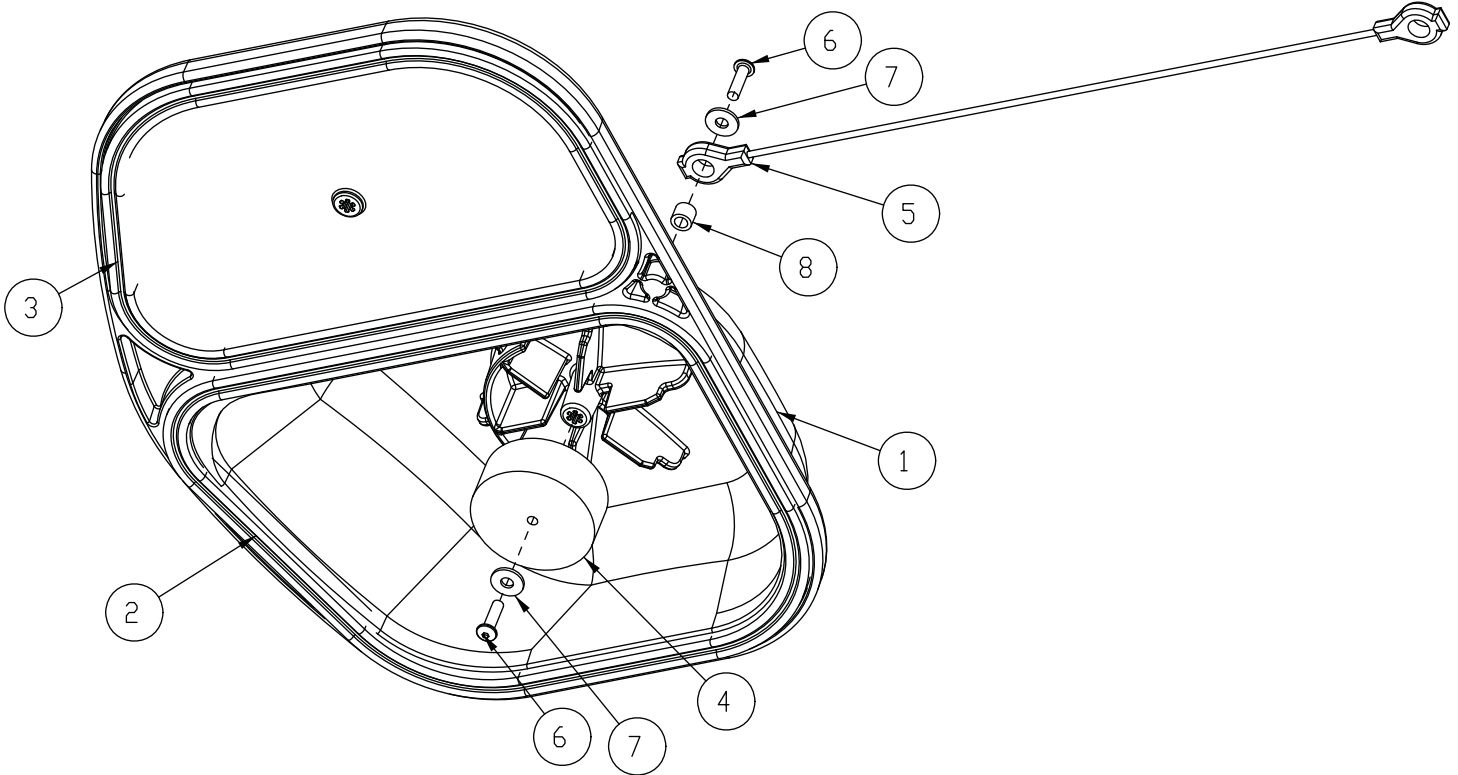

BILL OF MATERIAL - 173195

ITEM	PART NO.	QTY	DESCRIPTION
1	173175	1	RECOVERY DOME LID
2	173177	1	GASKET , X17 LID, RT
3	173178	1	GASKET , X17 LID, LFT
4	173186	1	FILTER, X17 DOME LID
5	173187	1	CABLE 12.0
6	712516	2	SCR-BHCS #8-32 x .62 SS
7	712764	2	WSR #10 SS
8	762410	1	BUSHING, .2 X .31 X .265 ALUM

Spray Bar Assembly

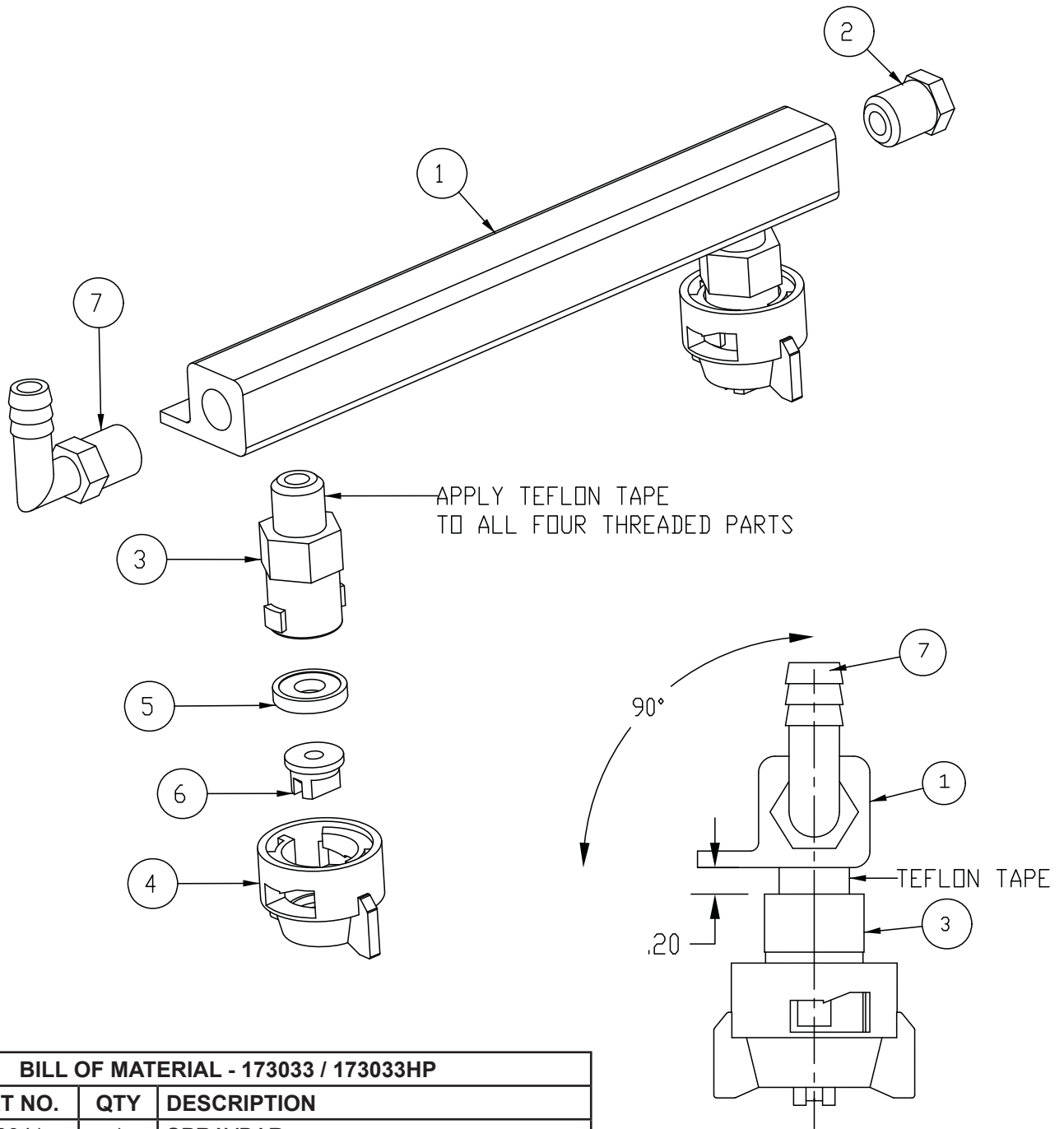

BILL OF MATERIAL - 173033 / 173033HP			
ITEM	PART NO.	QTY	DESCRIPTION
1	173041	1	SPRAYBAR
2	829619	1	END PLUG
3	833140	2	BODY INLET CONNECTOR
4	833141	2	CAP
5	833142	2	GASKET CAP
6	833145	2	SPRAY-NOZZLE, BRASS UNIJET 9504
	833143		SPRAYTIP 9505 100PSI (HI PRESSURE)
7	833325	1	FITTING NYLON 90 1/4MPT X 3/8HB

ORIENT FITTING (PN 833325) AND INLET CONNECTOR (833140) AS SHOWN (2X)

Handle Assembly (Pg 1 of 2)

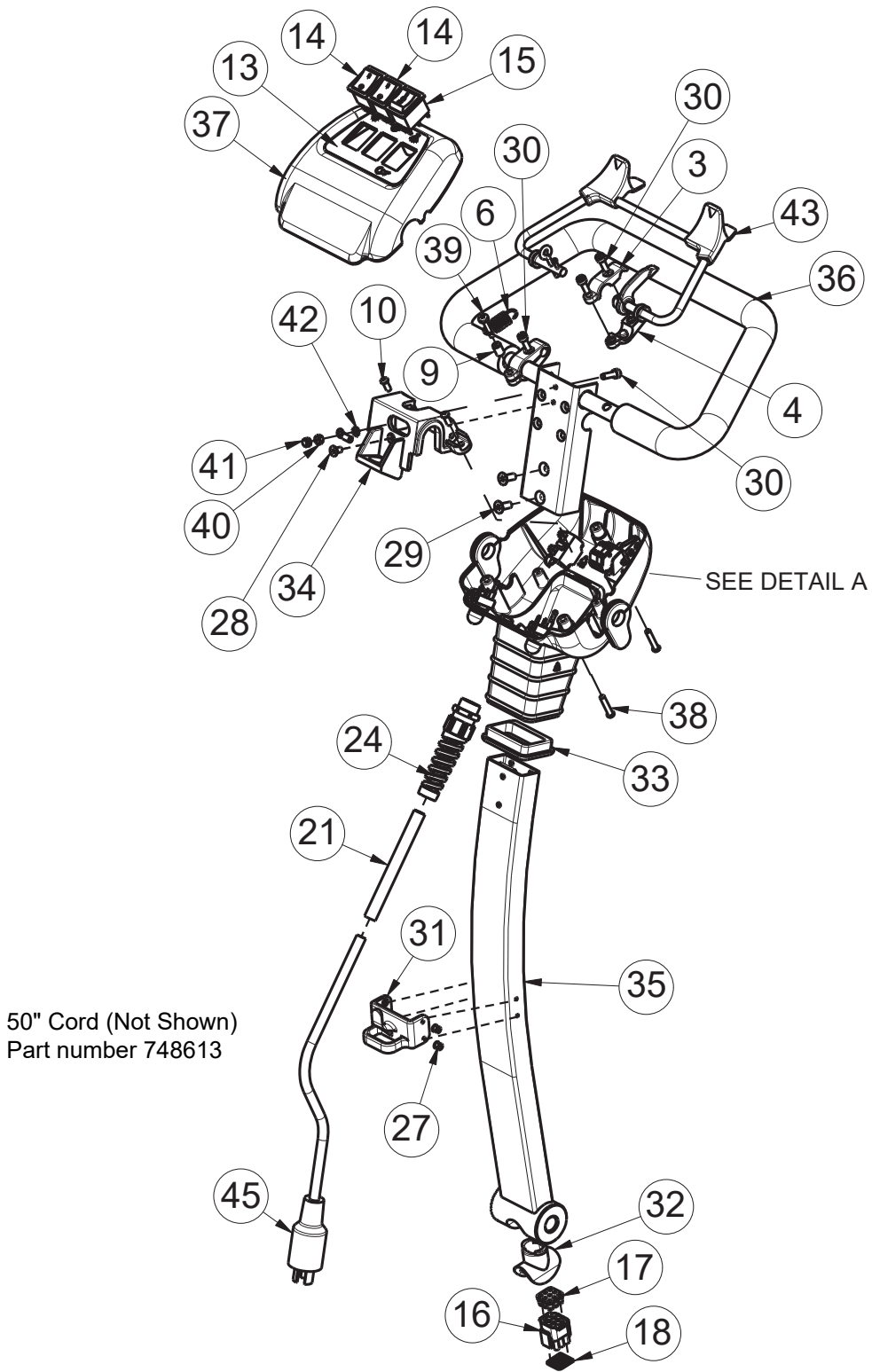

Handle Assembly (Pg 2 of 2)

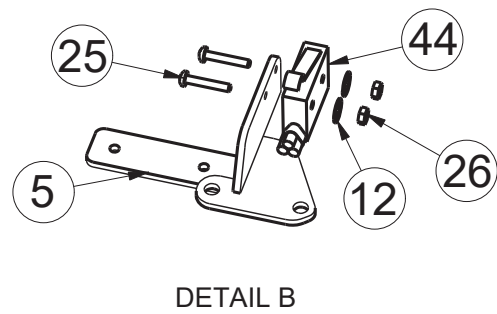
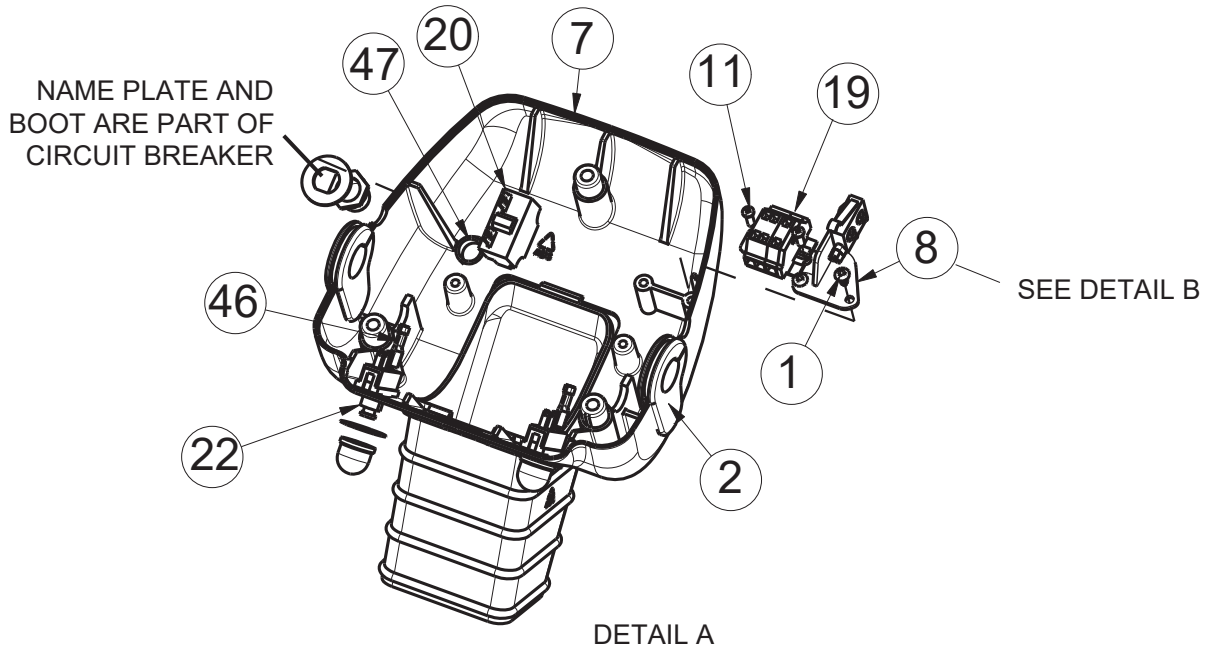

Handle Assembly BOM

BILL OF MATERIAL - 173200 (115V) / 173201 (230V)							
ITEM	PART #	QTY	DESCRIPTION	ITEM	PART #	QTY	DESCRIPTION
1	173064	2	SCR-ST PAN HD #6 x 3/8" SS	24	748701	1	CABLE GLAND
2	173161	2	GROMMET , HANDLE COVER	25	818719	2	SCR-MC PAN HD M2 X 12 ZP
3	173162	2	TOP BRKT-MOMENTARY HANDLE	26	823101	2	NUT-HEX M2X0.4 ZP
4	173163	2	BTM BRKT - MOMENTARY HNDL	27	827666	4	RIVET-POP
5	173185	1	BKT, LIMIT SWITCH MOUNT	28	829203	1	SCR-SC FH M5X10 SS
6	173203	1	SPRING-EXT 1.375 FL X .5 OD	29	829306	2	SCR-SC FH M6X16 SS
7	173210	1	COVER, HANDLE BOTTOM ASM	30	831206	4	SCR-SC M5X16 ZP
8	173214	1	LIMIT SWITCH ASSY, X17 HNDLE	31	931177	1	RETAINER, CORD
9	255045	1	SPACER, .196X.31X.47 ALUM	32	931182	1	BOOT, HANDLE LOWER
10	711163	2	SCR-HI/LO #10-16 X 1/2	33	931199	1	PLUG - HANDLE COVER
11	711686	2	SCR-MCM 3 X 10 ZP	34	3130072	1	BRACKET -CHANNEL
12	712326	2	WSR-INT LOCK #4	35	3180016	1	HANDLE ARM (WELDMENT)
13	715722	1	DECAL, DASHBOARD EX17	36	3180029	1	STEERING ASM
14	748602	2	SWITCH, DPST ON-OFF IP55	37	3180120	1	SWITCH COVER TOP - X17
15	748603	1	SWITCH, DPDT ON-OFF-ON IP55	38	3402036	3	SCR-HI/LO #10-16 X 1"
16	748605	1	CONNECTOR, 9P MALE	39	11175494	1	SCR-MC M5 X 25 SS DIN7985
17	748608	1	SEAL 9P MALE WIRE	40	12022430	1	NUT- HEX, M5, SS DIN934
18	748609	1	SEAL, 9P INTERFACE	41	12040036	1	NUT-NYLOC M5 X 0.8
19	748616	1	TERMINAL BLOCK, HANDLE ASM X17	42	12518080	1	EXTERNAL TOOTHED WASHER - M5
20	748620	1	CIRCUIT BREAKER, 12A SMALL (115V MODELS)	43	****	1	MOMENTARY HANDLE (REPLACE W/ K-HANDLESWITCH)
	748672		CIRCUIT BREAKER 7A SMALL 125-25 (230V MODELS)	44	748611-1	1	SWITCH ASY, MICROSWITCH W/QC
21	748649	1	TUBING, VINYL COATED 4.5"	45	748614-1	1	CORD, PIGTAIL ASM X17 115V (115V MODELS)
22	748695	2	CIRCUIT BREAKER, 1.5A 1410 (115V MODELS)		748614CE-1		CORD, PIGTAIL ASM X17 230V (230V MODELS)
	748696		CIRCUIT BREAKER, 1A 1410 (230V MODELS)	46	748697	2	QC-FEMALE 18-22G .110 FULL INSULATED
23	748700	1	WIRE HARN., HANDLE ASM - UL	47	830803	1	HEYCO PLUG BLACK 1/2"

Back Panel Assembly

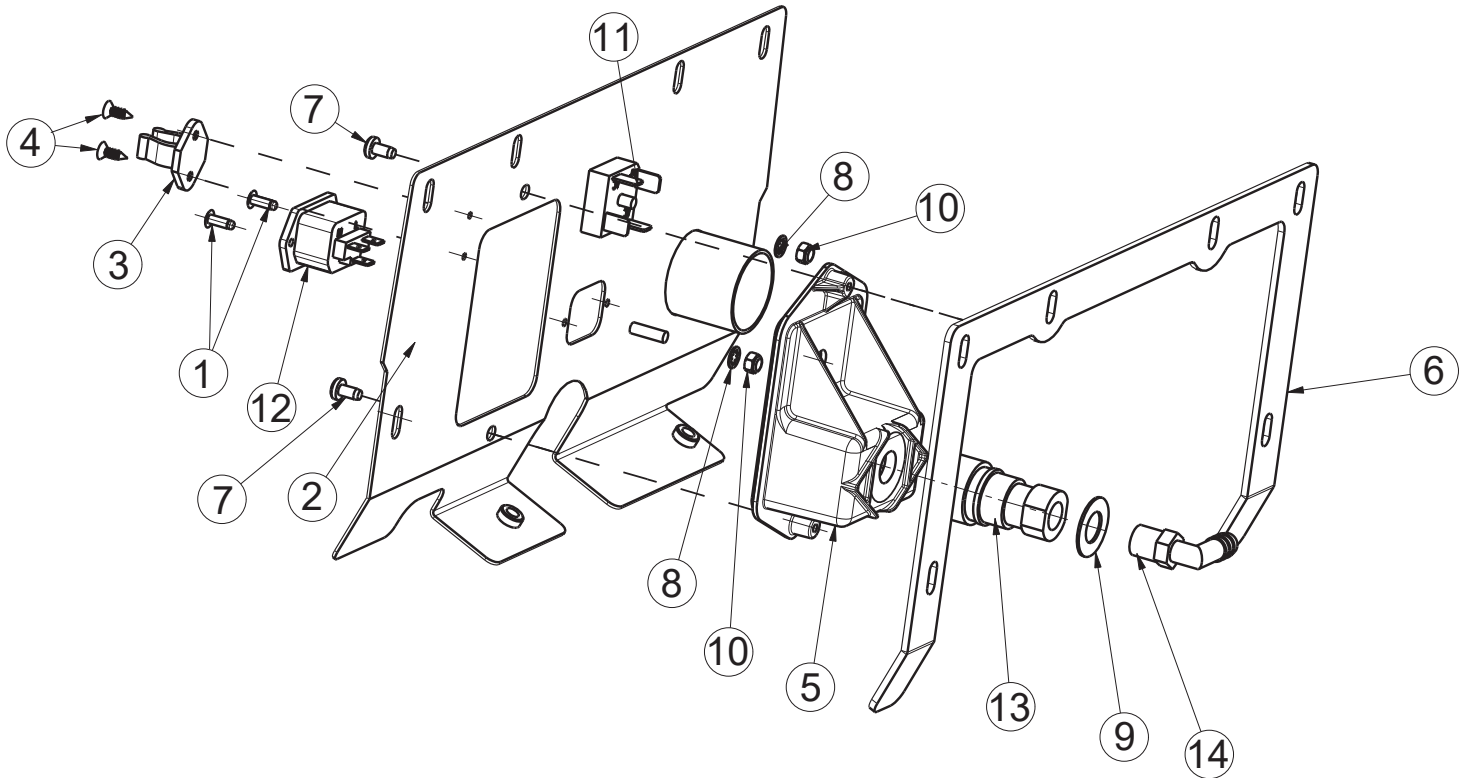

BILL OF MATERIAL - 173043

ITEM	PART NO.	QTY	DESCRIPTION
1	410-4419AA	2	RIVET-POP
2	173034	1	BACK PANEL WELDMENT
3	173048	1	CLIP, 1/2 - 3/8 IN HOSE
4	173098	2	SCR-ST FL HD 8 X 1/2" STL ZINC
5	173107	1	AUX-CONTROL PANEL
6	173169	1	GASKET, BACK PANEL
7	711124	2	SCR-ST-B 10 X .37 NI
8	711553	2	WSR-INT LOCK #10
9	712760	1	WSR-FLT .56 X 1.06 X .04 SS
10	717017	2	NUT-NYLOC M5 X .08
11	740202	1	RECTIFIER-BRIDGE 50A 600V IMP
12	741038	1	RECEPTACLE-10A 250VAC IEC 320
13	828370	1	COUPLER-FEMALE BH2-60
14	833325	1	FITTING NYLON 90 1/4MPT 3/8HOS

Chassis Sub-Assembly

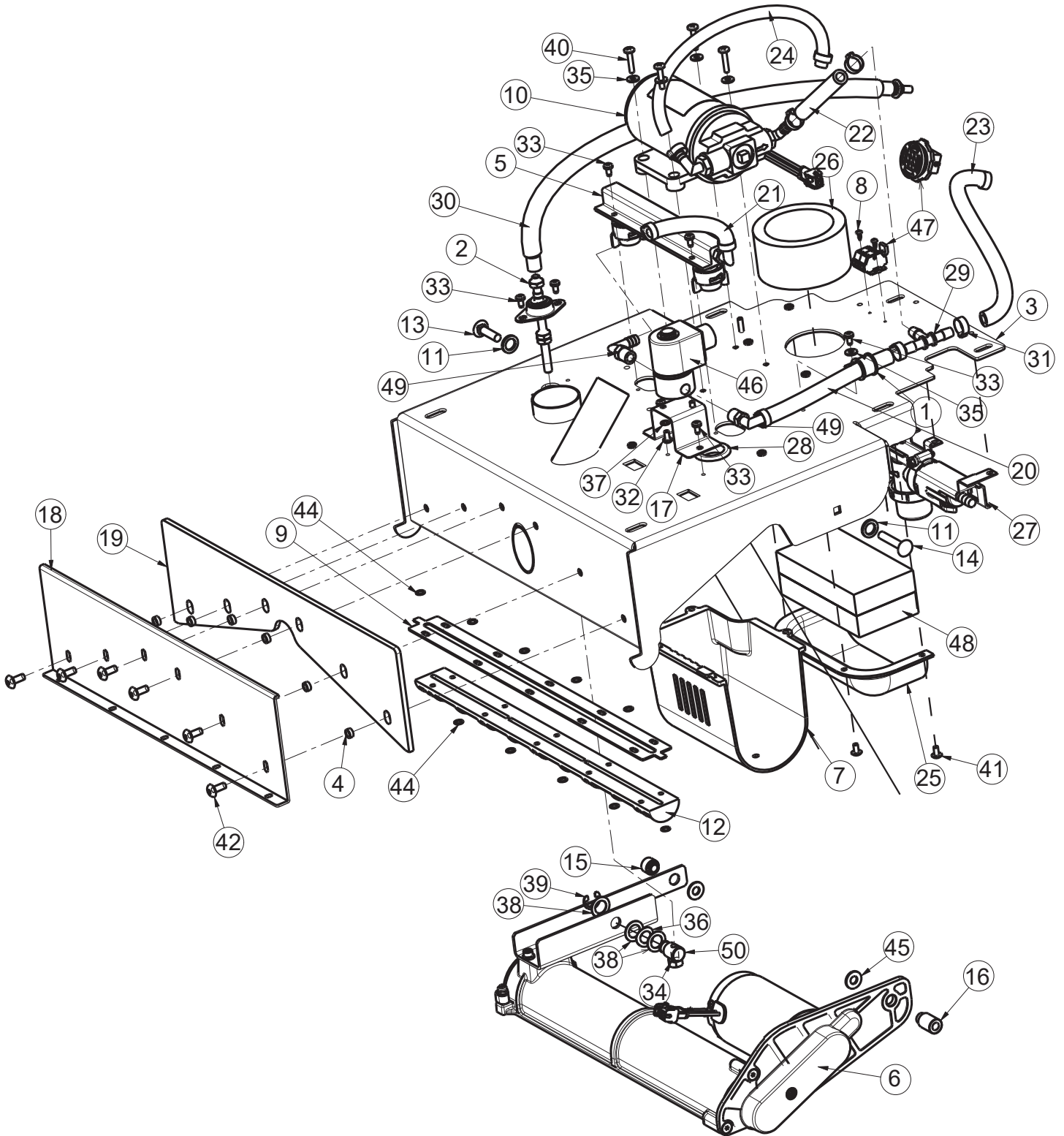

BILL OF MATERIAL - 173050 / 173050-HP / 173050-230 / 173050-230HP			
ITEM	PART #	QTY	DESCRIPTION
1	82-54-A	1	CLAMP, MS21333-114
2	7545-10	1	FLANGED BEARING ASSY
3	173004	1	MAINFRAME WELDMENT
4	173018	6	SPACER, FRONT PLATE
5	173033	1	EX17 - SPRAY BAR ASSEMBLY
	173033HP		EX17 - SPRAY BAR ASSEMBLY (HP MODELS ONLY)
6	173052	1	EX17 ECO SINGLE BRUSH ASSEMBLY (115V MODELS)
	173052-230		EX17 ECO SINGLE BRUSH ASSEMBLY (230V MODELS)
7	173061	1	GUARD, BRUSH MOTOR
8	173064	2	SCR-ST PAN HD #6 x 3/8" SS
9	173070	1	GASKET, VACUUM SHOE
10	173076	1	PUMP ASY, 115V 50PSI EX17-ECO (115V MODEL)
	173076-230		PUMP ASY, 230V 50PSI EX17-ECO (230V MODEL)
	173076HP		PUMP ASY, 115V 100PSI EX17-ECO (115V HP MODEL)
	173076-230HP		PUMP ASY, 230V 100PSI EX17-ECO (230V HP MODEL)
11	173078	2	WSR FLT 1/2 x 3/4 x .09 SS
12	173086	1	VACUUM SHOE, EX17 ECO
13	173096	1	CARRIAGE SCREWS 5/16-18 X 1-1/4 SS
14	173097	1	CARRIAGE SCREWS 5/16-18 X 1-3/4 SS
15	173108	1	BUSH, SIDE ARM
16	173109	1	BUSH, SIDE BRACKET
17	173113	1	WATER VALVE BRACKET
18	173120	1	FRONT SQUEEGEE PLATE
19	173146	1	FRONT PLATE NEOPRENE GASKET X17
20	173147	1	HOSE, 3/8 I.D x 7 IN
21	173148	1	HOSE, SPRAY BAR, 3/8 ID x 5.5 IN
22	173149	1	HOSE, PUMP 3/8 I.D x 4.5 IN
23	173150	1	HOSE, COUPLER 3/8 I.D x 12 IN
24	173151	1	HOSE, 3/8 ID x 17 IN

BILL OF MATERIAL - 173050 / 173050-HP / 173050-230 / 173050-230HP			
ITEM	PART #	QTY	DESCRIPTION
25	173218	1	SHROUD, FILTER / DIFFUSER
26	173220	1	SLEEVE / DUCT; VACUUM MOTOR COOLING
27	173222	1	ASSY, BALL-VALVE & FILTER; SHIELDED
28	220327	1	GROMMET 1.25 X 1 X .125
29	241726	1	NYLON SINGLE-BARBED TEE, 3/8"
30	452010	1	#160 2BLT FLG BRG W/3/8B
31	452037	10	CLAMP-CRIMP 170R SS
32	710353	2	SCR-MC RD HD 10-32 X .37 STL
33	711124	7	PAN HEAD ST #10 X .37 NI
34	711383	1	NUT-HEX CLR LOC 5/16-18
35	711503	5	WSR, FLAT#10
36	711524	1	WSR-WAVE .52 X .87 X .01
37	711553	2	WSR- INTERNAL LOCK #10
38	711594	3	WSR-FLAT .56 X .88 X .03
39	711713	1	RETAINING RING - "E" TYPE EXT .500
40	712532	4	SCR - MC, PAN HD, 10-24 X 1.00, SS
41	712540	4	SCR-THMS 10-24 X .37 SS
42	712559	6	SCR-TR 1/4-20 X .62 TORX TR HD
43	712638	5	NUT, HEX 10-24 SS NYLOC
44	712770	10	WSR INT LOCK #10A SS
45	712772	2	WSR-FLAT .344 x .75 x .06 SS
46	740492-1	1	VALVE ASY, SOLENOID 115V X17
	740240-1		SOLENOID ASY, WATER 240V 50HZ
47	748650	1	WIRE HARNESS, BASE ASM X17 115V (115V MODELS)
	748650-230		WIRE HARNESS, BASE ASM X17 230V (230V MODELS)
48	832220	1	FILTER / DIFFUSER, OPEN-CELL FOAM
49	833325	2	FTG-ELBOW 90 1/4 MPT X 3/8 HB NYLON
50	762257plt	1	NUT ADJ RH ZINC DICROMATE

Brush Head Assembly

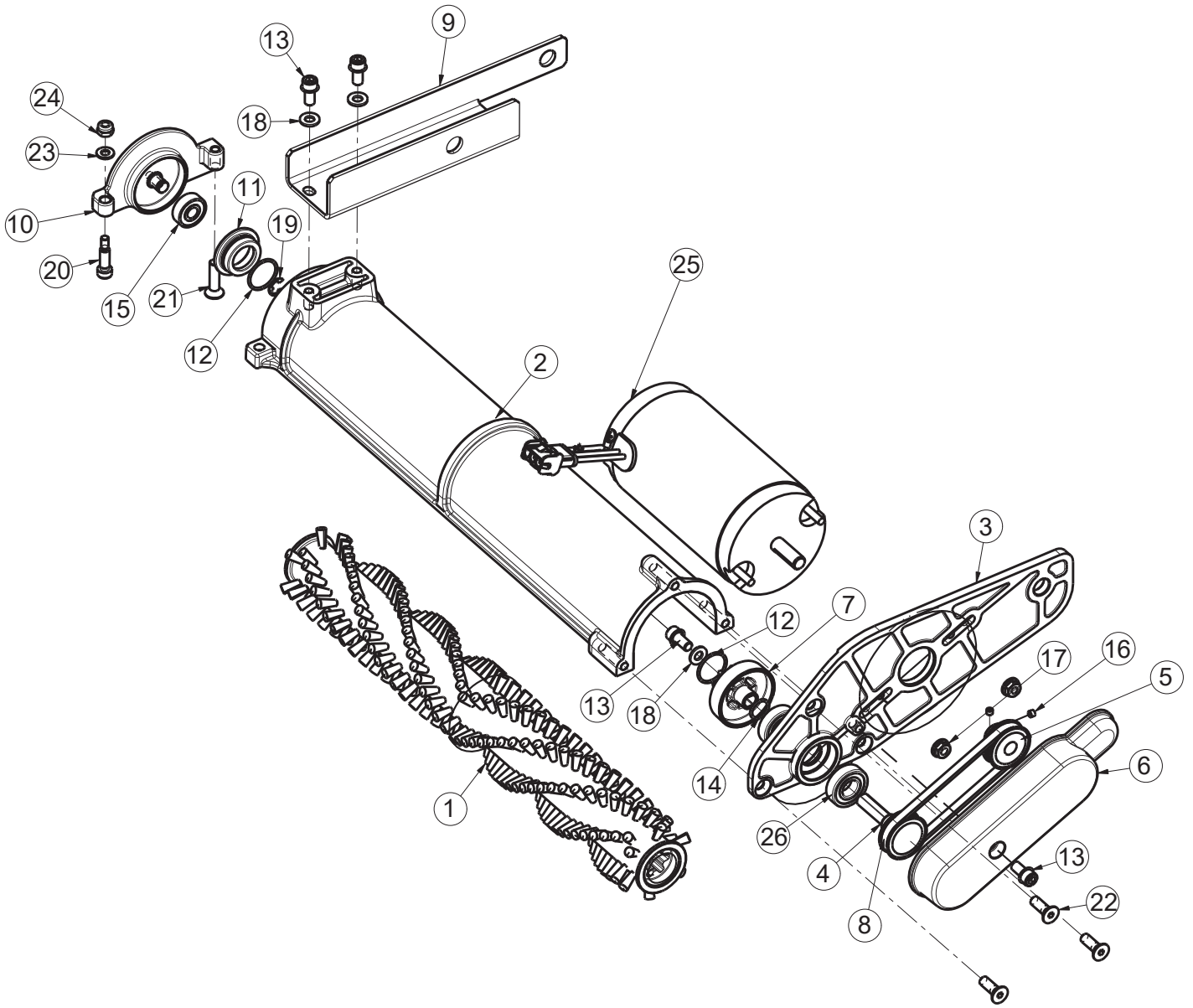

Brush Head Assembly BOM

BILL OF MATERIAL - 173052 / 173052-230			
ITEM	PART #	QTY	DESCRIPTION
1	173055	1	EX17 BRUSH CORE ASSEMBLY
2	173056	1	BRUSH BASE
3	173060	1	MOTOR BRACKET
4	173062	1	SPROCKET 30
5	173065	1	DRIVE SPROCKET ASSEMBLY
6	173066	1	COVER BELT
7	173067	1	DRIVE PULLEY
8	173068	1	BELT
9	173075	1	LIFT BRACKET
10	173094	1	BRUSH SIDE COVER
11	173095	1	IDLE PULLEY
12	173115	2	O-RING 20mm x 1.5mm
13	173145	4	SC - SHCS 1/4"-20 X 0.5 SS
14	173176	1	O-RING 12mm x 1.5mm
15	173208	1	BEARING-DBL SEALED 8X22X7
16	711001	2	SK 8-32 X .12
17	711427	2	NUT-FLANGED WIZZ 10-32
18	711566	3	WSR-FLAT .259 X .500 X .065
19	711721	1	RET RING-E TYPE .312
20	712151	1	BLT SHOULDER, 10-24 x 5/8 IN
21	712153	1	SC-SHCS, 1/4-20 x 1.00 IN SS
22	712154	3	SC-SHCS, 1/4-20 x 0.75, SS
23	712320	1	WSR-NYLON .22 X .45 X .04
24	712638	1	NUT, HEX 10-24 SS NYLOC
25	831238-2	1	BRUSH DRIVE MOTOR ASSEMBLY (115V MODELS)
	832611-2		MOTOR BRUSH 230V (230V MODELS)
26	875009	2	BEARING 12mm x 28mm DOUBLE SEALED

Valve-Filter Assembly

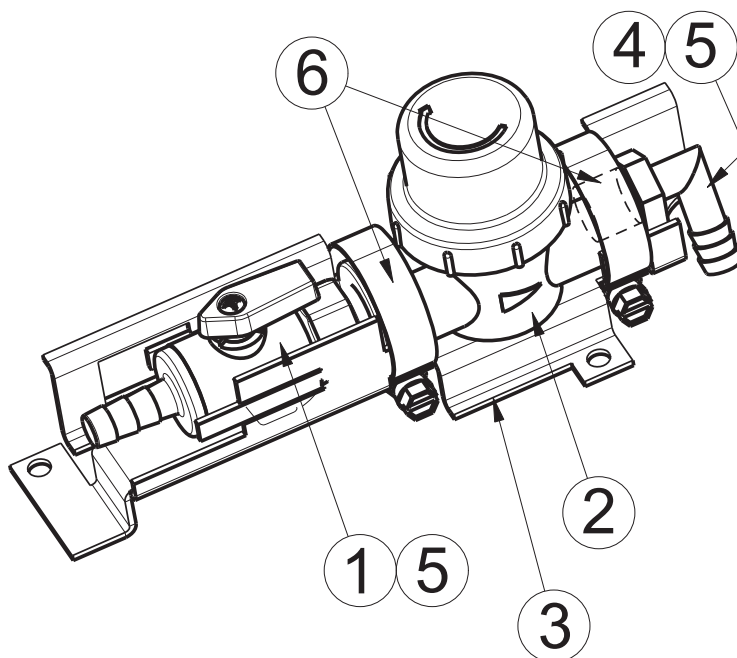

BILL OF MATERIAL - 173222			
ITEM	PART NO.	QTY	DESCRIPTION
1	173154	1	VALVE, BALL, 3/8 BARB x 3/8 MPT
2	173158	1	IN-LINE FILTER ASSEMBLY, 3/8 FNPT
3	173219	1	BRACKET, MTG, BALL VALVE & FILTER
4	450040	1	FTG-ELBOW 90 3/8 MPT X 3/8 HB NYLON
5	829552	1	TAPE-TEFLON PIPE 1/2"
6	3302193	2	CLAMP-HOSE 1.25 NOM

Pump Assembly

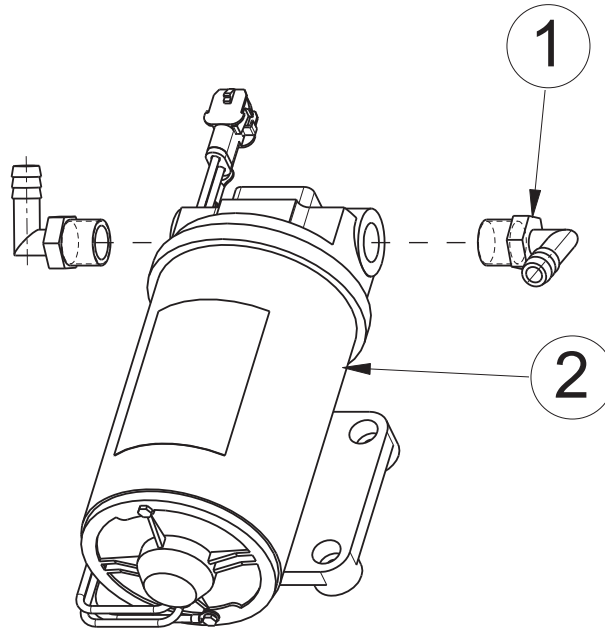

BILL OF MATERIAL - 173076

ITEM	PART NO.	QTY	DESCRIPTION	MODEL
1	450040	2	FITTING 90 3/8MPT X 3/8 BARB NYLON	
2	829757-1	1	PUMP ASY, BYPASS 115V 50PSI	X17115 MODEL ONLY
2A	742150-1	1	PUMP ASY, BYPASS 230V 50PSI	X17230 MODEL ONLY
2B	829757-1HP	1	PUMP ASY, BYPASS 115V 100PSI	X17115HP MODEL ONLY
2C	742150-1HP	1	PUMP ASY, BYPASS 230V 100PSI	X17230HP MODEL ONLY

Wiring Schematic 115V, Handle Assembly

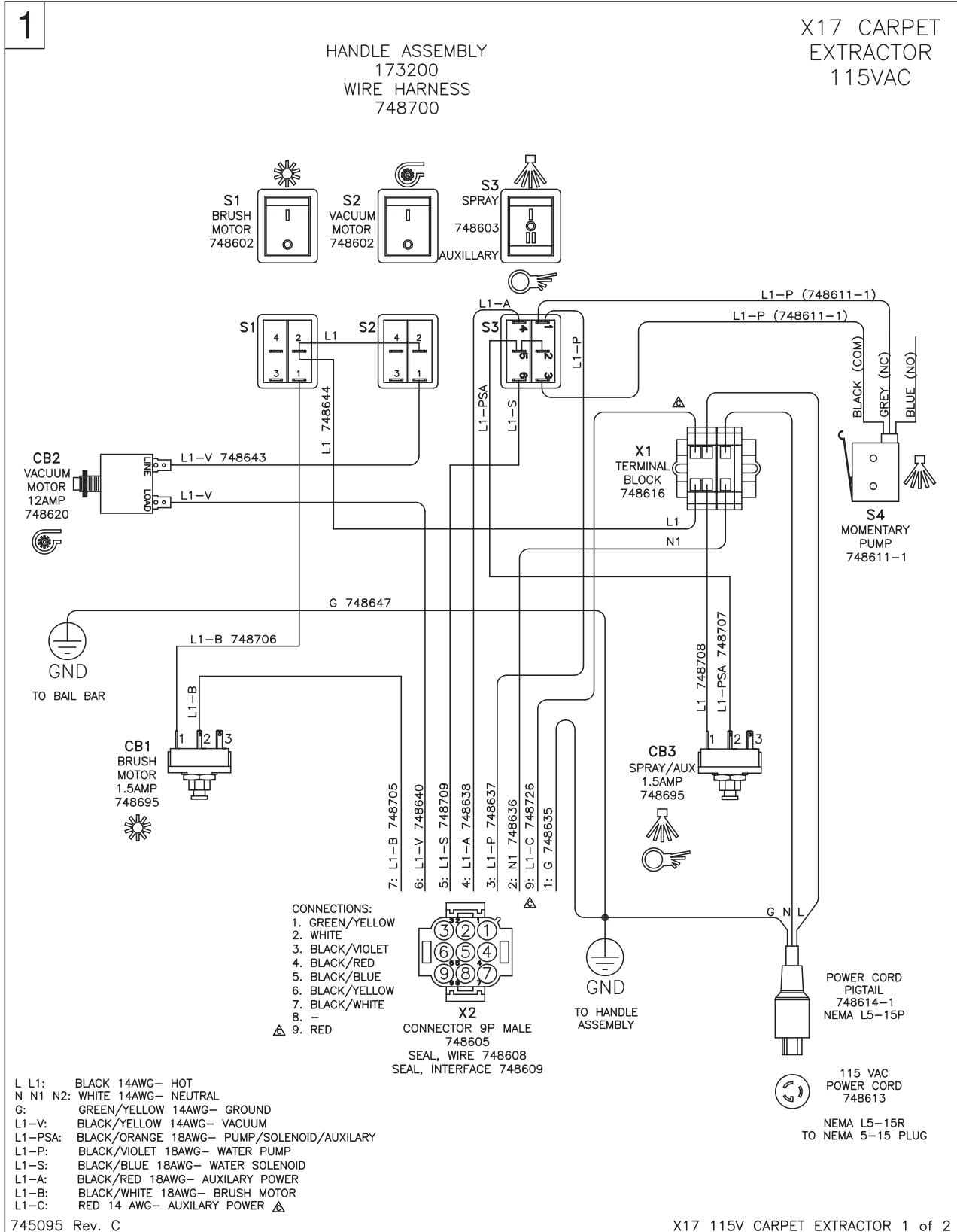

Wiring Schematic 115V, Wire Harness

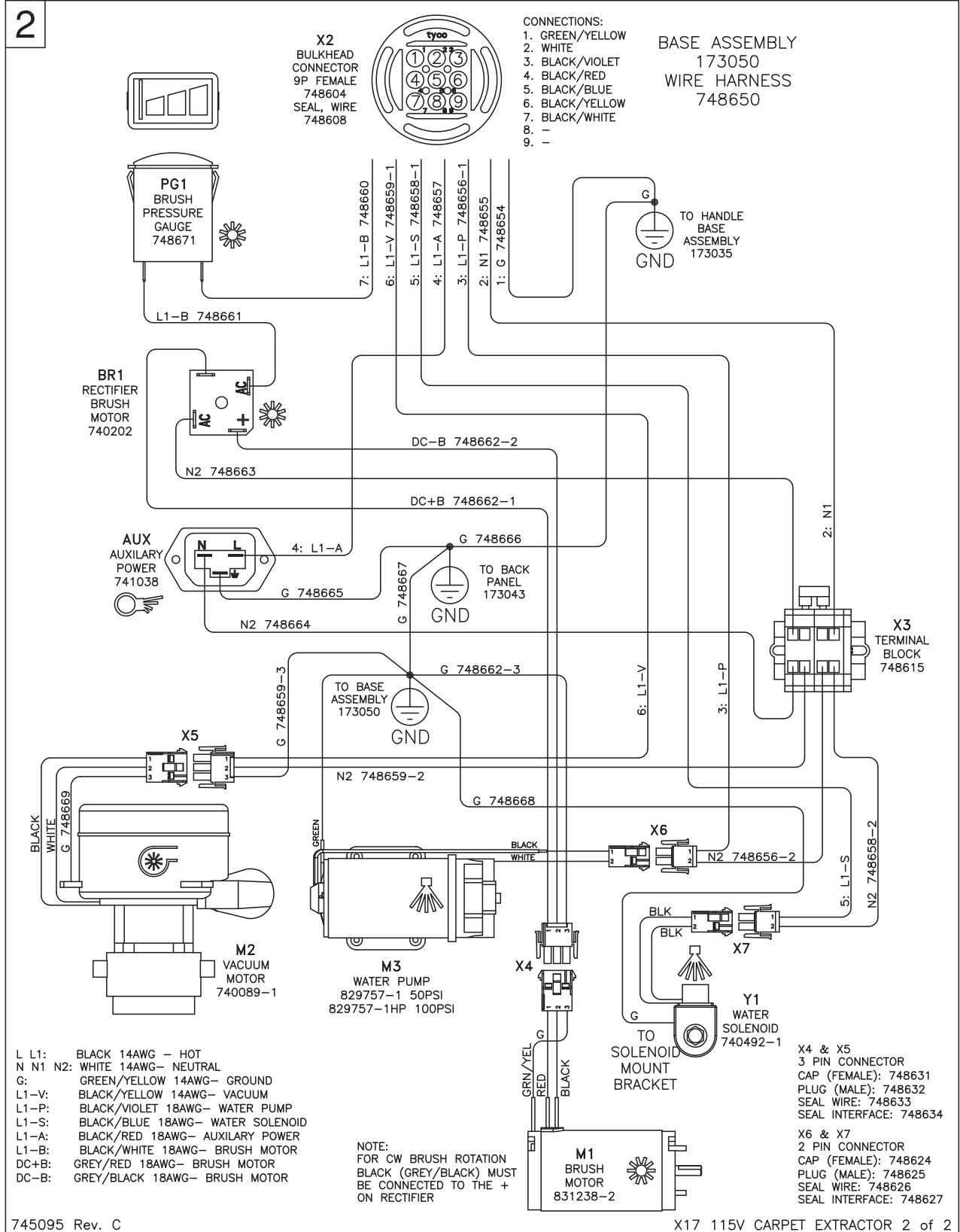

115V Electrical Schematic Reference Numbers

Reference #	Description	Part Number
S1	SWITCH, BRUSH MOTOR	748602
S2	SWITCH, VACUUM MOTOR	748602
S3	SWITCH, SPRAY & AUXILARY	748603
S4	SWITCH, MICRO MOMENTARY PUMP	748611-1
CB1	CIRCUIT BREAKER, 1.5A BRUSH MOTOR	748695
CB2	CIRCUIT BREAKER, 12A VACUUM MOTOR	748620
CB3	CIRCUIT BREAKER, 1.5A PUMP/SOLENOID & AUXILIARY	748695
M1	MOTOR, BRUSH	831238-2
M2	MOTOR, VACUUM	740089-1
M3	PUMP, WATER 50 PSI	829757-1
M3	OPTIONAL: PUMP, WATER 100 PSI	829757-1HP
Y1	SOLENOID, WATER	740492-1
PG1	GAUGE, BRUSH PRESSURE	748671
BR1	RECTIFIER, BRUSH MOTOR	740202
AUX	RECEPTACLE, AUXILARY POWER	741038
X1	TERMINAL BLOCK, HANDLE ASSEMBLY	748616
X2	CONNECTOR, 9 PIN BULKHEAD (FEMALE)	748604
part of X2	CONNECTOR, 9 PIN PLUG (MALE)	748605
part of X2	SEAL, WIRES 9 PIN	748608
part of X2	SEAL, INTERFACE 9 PIN	748609
X3	TERMINAL BLOCK, BASE ASSEMBLY	748615
X4 & X5	CONNECTOR, 3 PIN CAP (FEMALE)	748631
part of X4 & X5	CONNECTOR, 3 PIN PLUG (MALE)	748632
part of X4 & X5	SEAL, WIRES 3P	748633
part of X4 & X5	SEAL, INTERFACE 3 PIN	748634
X6 & X7	CONNECTOR, 2 PIN CAP (FEMALE)	748624
part of X6 & X7	CONNECTOR, 2 PIN PLUG (MALE)	748625
part of X6 & X7	SEAL, WIRES 2 PIN	748626
part of X6 & X7	SEAL, INTERFACE 2 PIN	748627

Wiring Schematic 230V, Handle Assembly

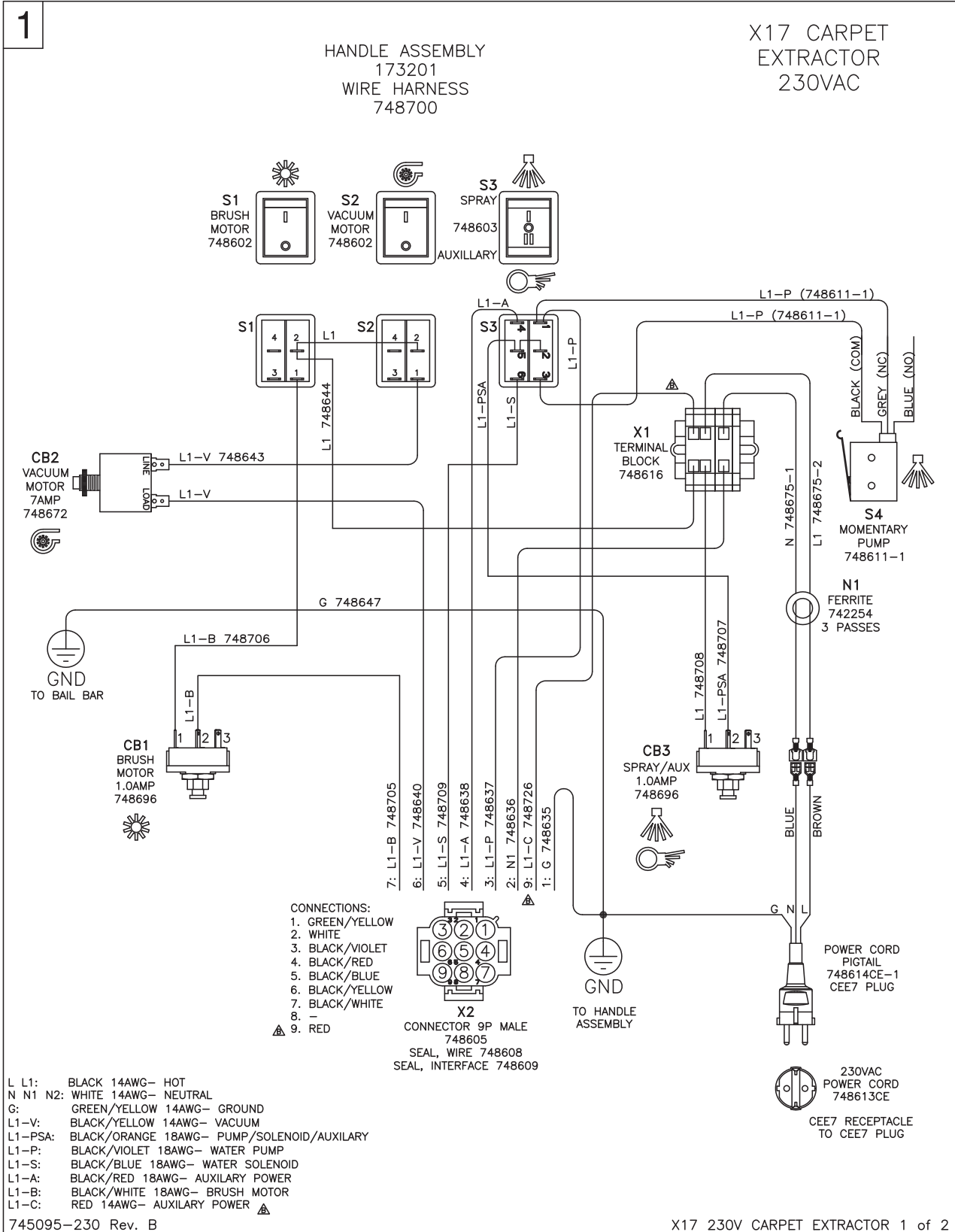

Wiring Schematic 230V, Wire Harness

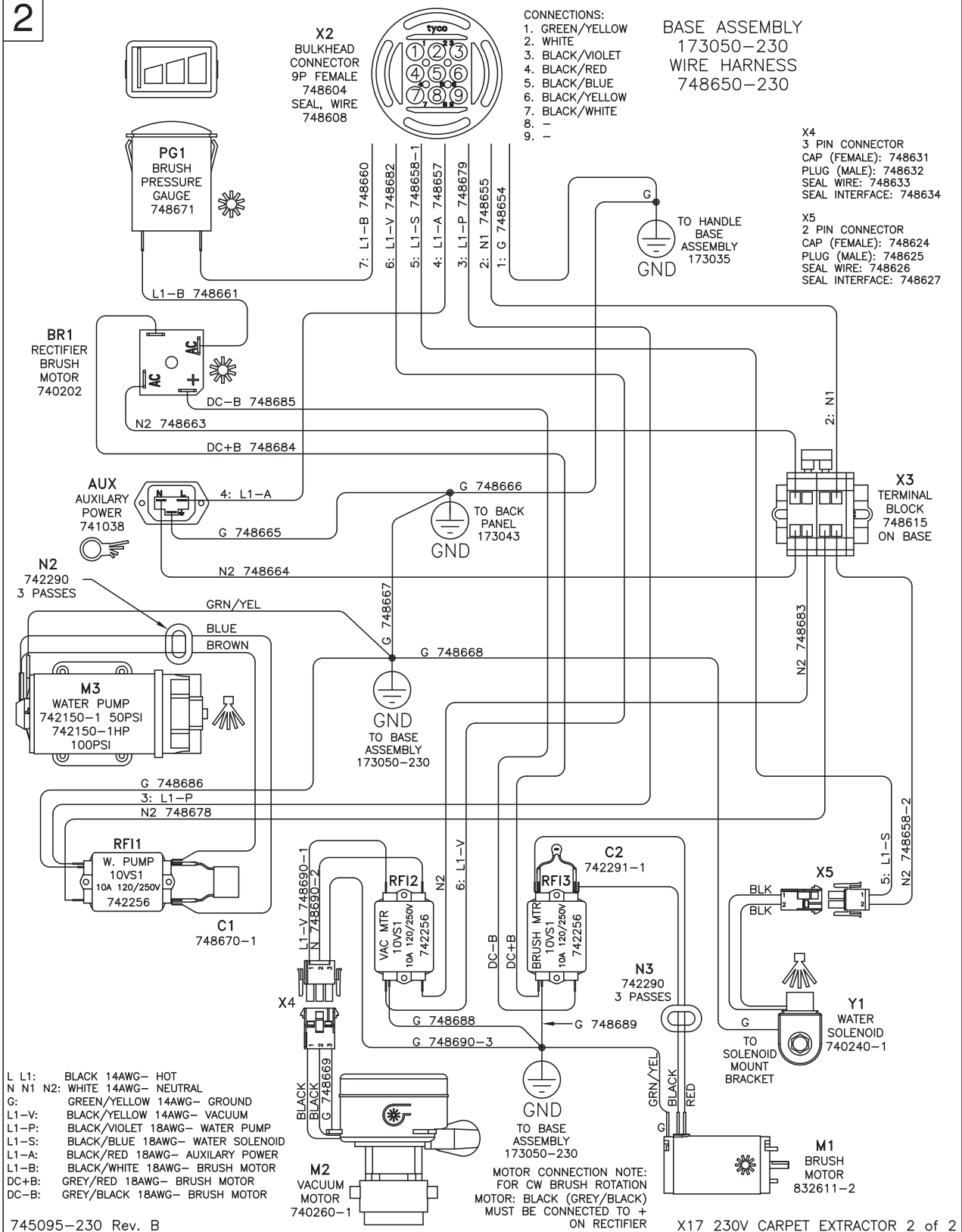

230V Electrical Schematic Reference Numbers

Reference #	Description	Part Number
S1	SWITCH, BRUSH MOTOR	748602
S2	SWITCH, VACUUM MOTOR	748602
S3	SWITCH, SPRAY & AUXILIARY	748603
S4	SWITCH, MICRO MOMENTARY PUMP	748611-1
CB1	CIRCUIT BREAKER, 1.0A BRUSH MOTOR	748696
CB2	CIRCUIT BREAKER, 7A VACUUM MOTOR	748672
CB3	CIRCUIT BREAKER, 1.0A PUMP/SOLENOID & AUXILIARY	748696
M1	MOTOR, BRUSH	832611-2
M2	MOTOR, VACUUM	740260-1
M3	PUMP, WATER 50 PSI	742150-1
M3	OPTIONAL: PUMP, WATER 100 PSI	742150-2
Y1	SOLENOID, WATER	740240-1
PG1	GAUGE, BRUSH PRESSURE 230VAC	748671
BR1	RECTIFIER, BRUSH MOTOR	740202
AUX	RECEPTACLE, AUXILIARY POWER	741038
RFI1	RFI FILTER, WATER PUMP	742256
RFI2	RFI FILTER, VACUUM MOTOR	742256
RFI3	RFI FILTER, BRUSH MOTOR	742256
C1	CAPACITOR ASM, 1uF WATER PUMP	748670-1
C2	CAPACITOR ASM, 330pF BRUSH MOTOR	742291-1
N1	FERRITE, LINE	742254
N2	FERRITE, WATER PUMP	742290
N3	FERRITE, BRUSH MOTOR	742290
X1	TERMINAL BLOCK, HANDLE ASSEMBLY	748616
X2	CONNECTOR, 9 PIN BULKHEAD (FEMALE)	748604
part of X2	CONNECTOR, 9 PIN PLUG (MALE)	748605
part of X2	SEAL, WIRES 9 PIN	748608
part of X2	SEAL, INTERFACE 9 PIN	748609
X3	TERMINAL BLOCK, BASE ASSEMBLY	748615
X4	CONNECTOR, 3 PIN CAP (FEMALE)	748631
part of X4	CONNECTOR, 3 PIN PLUG (MALE)	748632
part of X4	SEAL, WIRES 3P	748633
part of X4	SEAL, INTERFACE 3 PIN	748634
X5	CONNECTOR, 2 PIN CAP (FEMALE)	748624
part of X5	CONNECTOR, 2 PIN PLUG (MALE)	748625
part of X5	SEAL, WIRES 2 PIN	748626
part of X5	SEAL, INTERFACE 2 PIN	748627



Minuteman International Made Simple Commercial Limited Warranty

REVISION O EFFECTIVE 4/1/2016

Minuteman International, Inc. warrants to the original purchaser/user that the product is free from defects in workmanship and materials under normal use. Minuteman will, at its option, repair or replace without charge, parts that fail under normal use and service when operated and maintained in accordance with the applicable operation and instruction manuals. All warranty claims must be submitted through and approved by factory authorized repair stations.

This warranty does not apply to normal wear, or to items whose life is dependent on their use and care, such as belts, cords, switches, hoses, rubber parts, electrical motor components or adjustments. Parts manufactured by Minuteman are covered by and subject to the warranties and/or guarantees of their manufacturers. Please contact Minuteman for procedures in warranty claims against these manufacturers.

Special warning to purchaser -- Use of replacement filters and/or pre-filters not manufactured by Minuteman or its designated licensees, will void all warranties expressed or implied. A potential health hazard exists without original equipment replacement.

All warranted items become the sole property of Minuteman or its original manufacturer, whichever the case may be.

Minuteman disclaims any implied warranty, including the warranty of merchantability and the warranty of fitness for a particular purpose. Minuteman assumes no responsibility for any special, incidental or consequential damages.

This limited warranty is applicable only in the U.S.A. and Canada, and is extended only to the original user/purchaser of this product. Customers outside the U.S.A. and Canada should contact their local distributor for export warranty policies. Minuteman is not responsible for costs or repairs performed by persons other than those specifically authorized by Minuteman. This warranty does not apply to damage from transportation, alterations by unauthorized persons, misuse or abuse of the equipment, use of non-compatible chemicals, or damage to property, or loss of income due to malfunctions of the product.

If a difficulty develops with this machine, you should contact the dealer from whom it was purchased.

This warranty gives you specific legal rights, and you may have other rights which vary from state to state. Some states do not allow the exclusion or limitation of special, incidental or consequential damages, or limitations on how long an implied warranty lasts, so the above exclusions and limitations may not apply to you.

Model	Parts	Labor	Poly	Travel**
Cord Electric Group	5yrs	3yrs	12yrs	90 days
Battery Operated Group	5yrs	3yrs	12yrs	90 days

Exceptions.....

Model	Parts	Labor	Poly	Travel**
Port A Scrub, all models	1yr	6months	12yrs	90 days
A3S Blower	1yr	1yr	0	0
Phenom Dual Motor Upright Vacuums	2yrs	2yrs	0	0
Explosion Proof Vacuum	1yr	1yr	0	0
Propane Burnisher	1yr	1yr	0	90 days
**Travel, 2 hours max				

<i>Stand-alone Battery Chargers:</i>	One year
<i>Replacement Parts:</i>	Ninety days
<i>Batteries:</i>	0-3 months full replacement, 4-12 months pro-rate
<i>Polypropylene Plastic Tanks:</i>	12yr warranty, no additional labor

“Excellence Meets Clean”

**Minuteman is a Full Line Manufacturer of Sweepers and Scrubbers,
for Industrial Facilities.**



14N845 U.S. Route 20, Pingree Grove, IL 60140 USA
Phone (800) 323-9420 - www.minutemanintl.com
A Member of the Hako Group